

HIGH EFFICIENCY DOUBLE MOVEMENT BLENDER

FX series - Food & Additives



Blender patent No: ZL20162015-8

Revision date: Apr. 12, 2023



FEKMASS TECHNOLOGY INC
304, Building 2, No.81 North Jingsan road,
Zhengzhou 450000, China.
Tel: +86 371 87093270
www.fekmass.com
info@fekmass.com

SPECIAL BLENDER FOR FOOD & ADDITIVES

Light-duty type (100-1000L)

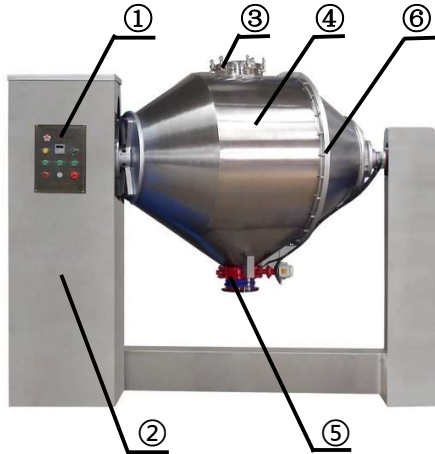

- ① Control panel
- ② Blender body
- ③ Feed inlet
- ④ Blender drum
- ⑤ Discharge outlet
- ⑥ Liquid spray system

Heavy-duty type (1500-7000L)

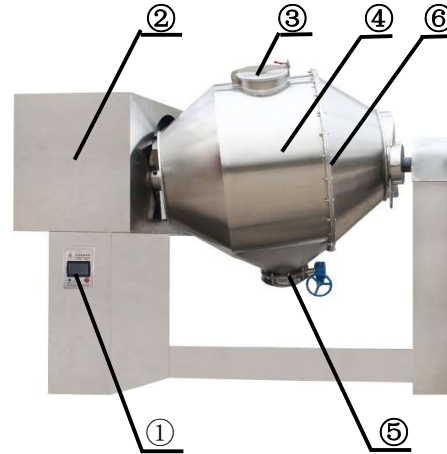

- ① Control panel
- ② Blender body
- ③ Feed inlet
- ④ Blender drum
- ⑤ Discharge outlet
- ⑥ Liquid spray system

Configuration:

Details	Standard configuration	Optional
① Control panel	Physical buttons	Touch screen
② Blender body	Stainless steel 304	Stainless steel 316
③ Feed inlet	Hand valve	Automatic valve
④ Blender drum	Stainless steel 304	Stainless steel 316
⑤ Discharge outlet	Hand valve	Automatic valve
⑥ Liquid spray system	None	Available

Notes:

Accept other custom made requirements.

WHY FEKMASS BLENDER ?

Double movement mixing, increase efficiency by 70%.

With 80% loading rate, very-high mixing uniformity.

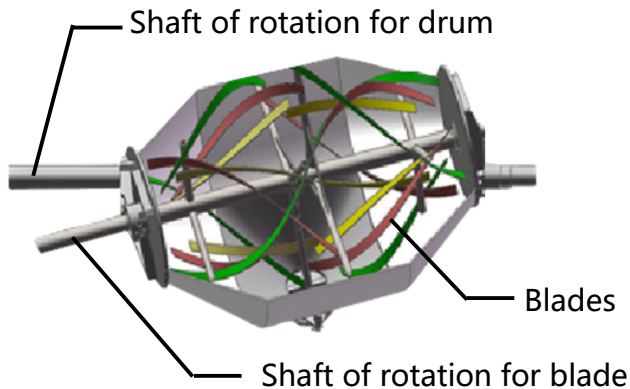

Our advantages:

- Double movement when mixing
- Special blade design
- Separate rotating for drum shaft
- Separate rotating for blade shaft

Features:

- Double movement mixing, very-high mixing uniformity
- High efficiency, save 70% mixing time
- High loading rate, 80% of the drum volume
- Meet the request of fine-scale mixing for new materials
- Does not damage the shape of the original particle
- The light powder and heavy powder are easy to mix evenly
- The trace elements are easy to mix evenly

Compared with other blenders:



V type mixer
Small volume
45% low loading rate



3-Dimensional blender
Small volume
40% low loading rate



Single cone mixer
Volum < 5000L
60% loading rate



Ribbon mixer
Bad mixing uniformity
65% loading rate



FEKMASS FX blender
Volume up to 15000L
80% loading rate

WHAT MATERIALS CAN BE MIXING ?

Application area & Materials

- Food
- Food additives
- Pet food
- Pharmaceutical
- Pharmaceutical intermediates
- Health products
- Cosmetic
- Pesticide
- Fertilizer
- Chemicals
- Diamond superhard material
- Dyestuff/Pigment
- Fingernail oil
- Life science
- Environment



SELECT YOUR SUITABLE MODEL

Model	Drum Volume (L)	Loading Volume (L)	Loading Weight (Kgs)	Drum rotation speed (r/min)	Blade rotation speed (r/min)	Motor (Kw)	Dimension (mm)	Total weight (Kgs)
FX-100	100	75	110	23	46	1.1	1700*720*1200	500
FX-200	200	150	240	21	42	2.2	2050*830*1400	660
FX-400	400	300	500	21	42	3	2500*1010*1600	910
FX-600	600	450	700	17/14	34/28	3/5.5	2700*1120*1750	1200
FX-800	800	600	1400	14	28	5.5	2900*1200*1850	2000
FX-1000	1000	800	1800	11	22	7.5	2550*1350*1900	2300
FX-1500	1500	1200	3000	8	16	15	2850*1870*2240	2600
FX-2000	2000	1600	4000	6	12	18.5	3200*1970*2470	2900
FX-3000	3000	2400	5000	6	12	22	3800*2100*2900	3500
FX-5000	5000	4000	6000	5.5	11	30	4500*2500*3200	4500
FX-7000	7000	5600	7000	5	10	37	4750*2650*3800	6000

Notes:

Above dimensions are for reference only.
Accept custom size and larger size.

AFTER-SALES SERVICE

Warranty service: 1 year

Strong technical team, Professional after-sales service

Help you solve any difficulties during the mixing process.



CONTACT FEKMASS

FEKMASS TECHNOLOGY INC
304, Building 2, No.81 North Jingsan road,
Zhengzhou 450000, China.
Tel: +86 371 87093270
www.fekmass.com
info@fekmass.com